



PMS 11

Particle Counter Specifications



Table of Contents

1. Overview.....	3
2. Working Principle.....	4
3. Technical Specifications.....	5
4. Electrical Specifications.....	6
5. Communication Protocol.....	7
6. Dimension.....	15
7. Precautions for Installation and Operation.....	16
8. Notice and Warning.....	17

1. Overview

PMS 11 series is an embedded and remote particle counter specially designed to provide solutions for the online monitoring industry of atmospheric environment. It is widely used in filter testing, dust monitoring and other air monitoring systems.



Pin	Name	Description	Note
1	VCC	Device power supply (positive)	12V
2	GND	Device grounding	---
3	TX(A)	Communication sending pin	(RS485+) serial sending
4	RX(B)	Communication receiving pin	(RS485-) serial receiving
5	NC	---	---

Table 1 Definition of Hardware Interface

2. Working Principle

This monitor relies on MIE scattering principle to monitor the concentration of particles. When the outside air passes through the light collection chamber uniformly, the particles in the sampled gas will scatter through the light beam. The photoelectric collection unit converts the scattered light signal into a voltage pulse signal, which is converted into a digital signal after pre-amplification and AD conversion. The number of voltage pulses measured is the number of particles, and the amplitude of voltage pulses reflects the size of optical equivalent size of particle. The standard substance is used to calibrate the monitor after the particle conversion, so as to determine the concentration of particles in the testing environment.

2.1 MIE scattering principle

A scattering occurred when the diameter of particles in the atmosphere is equal to the wavelength of radiation is called the MIE scattering. The scattering intensity of MIE scattering is inversely proportional to the second power of the wavelength. Unlike Rayleigh scattering enjoying a symmetrical distribution, MIE scattering has stronger scattering in the forward direction than in the backward direction, with a more obvious directivity.

2.2 Optical-mechanical structure and principle

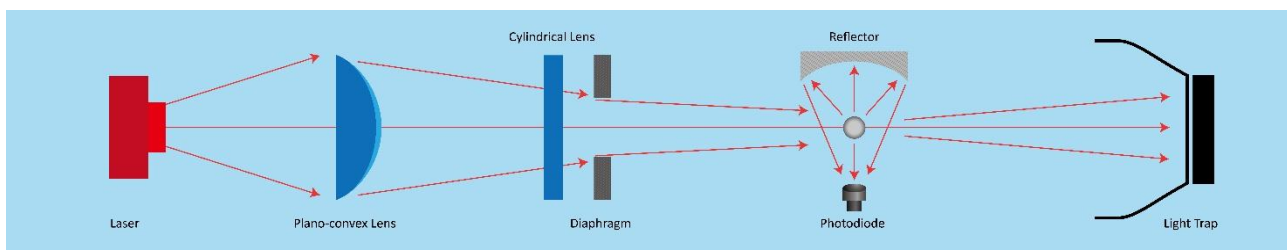

Fig. 1 Analysis Chart of Light Refraction

3. Technical Specifications

PMS 11		Unit	Note
Particle Size Range	0.3μm,0.5μm, 0.7μm, 1.0μm, 2.5μm, 5.0μm	P/L	Customize
Concentration Range	105,900	P/L	
Repeatability	≤±30% of Relative Standard Deviation	-	-
Resolution	1	P	-
Light Source	Laser Diode	-	-
Sampling Period	6	s	
Communication	RS485	-	
Flow Rate	1.1 (0.04)	L/min (CFM)	Accuracy ±5%
Weight	350	g	-
Operation Environment	5 ~45 , <90%RH	-	
Storage Environment	-10 ~50 , <90%RH	-	
Size	113*88*38	mm	Excluding air inlet and outlet

Table 2 Specifications of Particle Counter PMS 11

4. Electrical Specifications

4.1 Electrical properties

Standard output (Temperature 25 °C, Humidity 0-50% RH and 12V power supply voltage).

Parameters	Values	Unit
Rated voltage	DC 12	V
Standby current	30	mA
Average current	350	mA
Maximum current	400	mA
Starting current	700	mA
High-level input voltage	6	V
Low-level input voltage	-6	V
High-level output voltage	6	V
Low-level output voltage	-6	V

Table 3 Electrical Properties

4.2 Absolute limit values

The reliability of the device may be affected under the limit conditions for a long time.

Exceeding the following parameters range (Table 4) may cause permanent damage to the device.

Parameters	Range
Power supply voltage	11.5-12.5V
Voltage at I/O pin	-6-6 V
Working temperature range	-10-60 °C
Storage temperature range	-20-70 °C
Working humidity range	0-95%RH (non-condensation)
Lightning surge	2KV
Static electricity	1KV for terminal test; 8KV for test voltage of other surfaces

Table 4 Absolute Limit Values

5. Communication Protocol

UART parameters:

- Baud rate: 9600
- Data bit: 8
- Check bit: None
- Stop bit: 1

Communication mode:

- RS485 (Modbus RTU)

Address:

- The default factory address of the monitor is 0x01 (or 0xFE, as Any Sensor).

Command mode:

- The slave (monitor) is in the receiving state, only responding to the command of the host, not actively sending the command. As the monitor needs 6 seconds to start, it will NOT response to any command after the waiting time elapse.

Working mode:

- Continuous measurement: The monitor works continuously.
- Intermittent mode: The sampling time/sampling interval can be set (The intermittent time can be set by the users, and the monitor normally responds to the command of the host during the intermittent mode)
- The default factory setting of the monitor is intermittent mode, measuring for 60 seconds and stopping for 60 seconds.

Checksum:

- CRC-16(Modbus), with high bytes before low bytes.

5.1 Format of host communication protocol

Restrictions:

1. Read-only register and read-write register are not allowed to overlap.
2. Bit addressing (coil and discrete input) cannot be realized.
3. Only achieved writing the single register function, writing multi-register is not supported.
4. The total number of registers is limited; it currently supports 32 input registers and 32 hold registers.
5. The current version does not support file transfer with large amount of data.
6. See table 1 and table 2 for register details. All registers are 16-bit words and register address is register number -1.

See Table 5 for the description of Input Register.

Data No.	Address	Definition
IR1	0	For later extended use
IR2	1	For later extended use
IR3	2	For later extended use
IR4	3	>0.3μm, high bytes
IR5	4	>0.3μm, low bytes
IR6	5	>0.5μm, high bytes
IR7	6	>0.5μm, low bytes
IR8	7	>0.7μm, high bytes
IR9	8	>0.7μm, low bytes
IR10	9	>1.0μm, high bytes
IR11	10	>1.0μm, low bytes
IR12	11	>2.5μm, high bytes
IR13	12	>2.5μm, low bytes
IR14	13	>5.0μm, high bytes
IR15	14	>5.0μm, low bytes
IR16	15	For later extended use

IR17	16	For later extended use
IR18	17	For later extended use
IR19	18	For later extended use
IR20	19	For later extended use
IR21	20	For later extended use
IR22	21	For later extended use
IR23	22	For later extended use
IR24	23	For later extended use
IR25	24	For later extended use
IR26	25	For later extended use
IR27	26	For later extended use
IR28	27	For later extended use
IR29	28	For later extended use
IR30	29	For later extended use

Table 5 Input Register

See Table 6 for the description of save register.

Data No.	Address	Definition	Meaning	
IR1	0		For later extended use	
IR2	1	Special command register	Command	
			0x7C	Parameter
				0x06 Start Measurement
0x07 Stop Measurement				
IR3	2	Address setting register	Slave Address (1-247)	
IR4	3	Mode switching register	0x00 Continuous Working Mode	
			0x01 Intermittent Working Mode	
IR5	4	Sample interval register	0xxx Sample interval setting (20~3600s)	
IR6	5	Intermittent interval register	0xxx Intermittent interval setting (20~3600s)	
IR7	6	0.3µm particle calibration coefficient	User computing coefficient multiply by 10,000 (2000-65535)	
IR8	7	0.5µm particle calibration coefficient	User computing coefficient multiply by 10,000 (2000-65535)	
IR9	8	0.7µm particle calibration coefficient	User computing coefficient multiply by 10,000 (2000-65535)	

IR10	9	1.0µm particle calibration coefficient	User computing coefficient multiply by 10,000 (2000-65535)
IR11	10	2.5µm particle calibration coefficient	User computing coefficient multiply by 10,000 (2000-65535)
IR12	11	5.0 µm particle calibration coefficient	User computing coefficient multiply by 10,000 (2000-65535)
IR13	12		For later extended use
IR14	13		For later extended use
IR15	14		For later extended use
IR16	15		For later extended use
IR17	16		For later extended use
IR18	17		For later extended use
IR19	18		For later extended use
IR20	19		For later extended use
IR21	20		For later extended use
IR22	21		For later extended use
IR23	22		For later extended use
IR24	23		For later extended use
IR25	24		For later extended use
IR26	25		For later extended use
IR27	26		For later extended use
IR28	27		For later extended use
IR29	28		For later extended use
IR30	29		For later extended use
IR31	30		For later extended use
IR32	31		For later extended use

Table 6 Description of Save Register

5.2 Format of host communication protocol

The response length of slave is not fixed and changed according to the command of host (Table 7).

Start symbol 1	Start symbol 2	Slave address	Command	High data length	Low data length	High data 0	Low data 0
0x4A	0x43	ADDR	CMD	LENH	LENL	DATA0H	DATA0L
High data 1	Low data 1	High data N	Low data N	High check	Low check
DATA1H	DATA1L	DATANH	DATANL	0xXX	0xXX

Table 7 Response Format of Slave

Note: The address/function code is defined by the host (After modifying the device address, the address in the protocol is updated to the new address); see 5.3 command example for the specific response data of slave.

5.3 Command examples

Application Conditions:

- Assume as a single sensor (any sensor, use address 254)
- The value is hexadecimal data
- Take the address bit as 0xFE for example

5.3.1 Obtaining the concentration value

Read the number of particles above 0.3 μm, 1.0 μm, 2.5 μm.

Example:

number of particles above 0.3μm: 0x00002316 (actual value is 8982 P/L),
 number of particles above 1.0μm: 0x00001016 (actual value is 4118 P/L),
 number of particles above 2.5μm: 0x00000616 (actual value is 1558 P/L).

Host	Read the number of particles above 0.3μm: 0xFE 0x04 0x00 0x03 0x00 0x02 0x95 0xC4
	Read the number of particles above 0.7μm: 0xFE 0x04 0x00 0x04 0x00 0x02 0x24 0x05
	Read the number of particles above 2.5μm: 0xFE 0x04 0x00 0x05 0x00 0x02 0x75 0xC5

Slave	Read the number of particles above 0.3µm: 0xFE 0x04 0x04 0x00 0x00 0x23 0x16 0x6C 0x75
	Read the number of particles above 0.7µm: 0xFE 0x04 0x04 0x00 0x00 0x10 0x16 0x78 0x85
	Read the number of particles above 2.5µm: 0xFE 0x04 0x04 0x00 0x00 0x06 0x16 0x76 0xE5

Read the number of particles above 0.3µm, 0.5µm, 1.0µm, 2.5µm, 5.0µm.

Example:

number of particles above 0.3µm: 0x00002316 (actual value is 8982 P/L),
 number of particles above 0.5µm: 0x00001D4C (actual value is 7500P/L),
 number of particles above 0.7µm: 0x00001914 (actual value is 6420P/L),
 number of particles above 1.0µm: 0x00001016 (actual value is 4118P/L),
 number of particles above 2.5µm: 0x00000616 (actual value is 1558P/L),
 number of particles above 5.0µm: 0x00000140 (actual value is 320P/L).

Host	0xFE 0x04 0x00 0x03 0x00 0x0C 0x14 0x00
Slave	0xFE 0x04 0x18 0x00 0x00 0x23 0x16 0x00 0x00 0x1D 0x4C 0x00 0x00
	0x19 0x14 0x00 0x00 0x10 0x16 0x00 0x00 0x06 0x16 0x00 0x00 0x01
	0x40 0x40 0xD8

5.3.2 Start/Stop

After the host sends the **Start/Stop** command, the slave performs the corresponding action and returns the response command.

Example:

Host	Start Measurement: 0xFE 0x06 0x00 0x01 0x7C 0x06 0x6C 0XC7
	Stop Measurement: 0xFE 0x06 0x00 0x01 0x7C 0x07 0xAD 0X07

Slave	Start Measurement:
	0xFE 0x06 0x00 0x01 0x7C 0x06 0x6C 0xC7
	Stop Measurement:
	0xFE 0x06 0x00 0x01 0x7C 0x07 0xAD 0X07

5.3.3 Setting Slave Address

After the host sends the **Setting Slave Address** command, the slave performs the corresponding action and returns the response command.

Example:

Host	0xFE 0x06 0x00 0x02 0x00 0x03 0x7C 0X04
Slave	0xFE 0x06 0x00 0x02 0x00 0x03 0x7C 0X04

5.3.4 Read Device Address

After the host sends the **Read Device Address** command, the slave performs the corresponding action and returns the response command.

Example: The Device address is 03.

Host	0xFE 0x03 0x00 0x02 0x00 0x01 0x31 0xC5
Slave	0xFE 0x03 0x02 0x00 0x03 0xEC 0x51

5.3.5 Switching Continuous/Intermittent Working Mode

After the host sends the **Switching Continuous/Intermittent Working Mode** command, the slave performs the corresponding action and returns the response command.

Example:

Host	Continuous Working Mode:
	0xFE 0x06 0x00 0x03 0x00 0x00 0x6D 0XC5
	Intermittent Working Mode:
	0xFE 0x06 0x00 0x03 0x00 0x01 0xAC 0X05
Slave	Continuous/Intermittent Mode:
	0xFE 0x06 0x00 0x03 0x00 0x00 0x6D 0XC5
	Intermittent Working Mode:
	0xFE 0x06 0x00 0x03 0x00 0x01 0xAC 0X05

5.3.6 Write Hold Register Continuously

The calibration coefficient must be written continuously if using the 0x10 function, the 0x10 can only be used to write registers. Using the 03 function code can read the calibration coefficient.

Example: The actual coefficient is **k(0.3µm):1.2345 k(0.5µm):1.2345 k(0.7µm):1.2345**

k(1.0µm):1.2345 k(2.5µm):1.2345 k(5.0µm):1.2345

The coefficient that need to send is **1.2345*10000 = 12345 = 3039 (hexadecimal)**

Host	0xFE 0x10 0x00 0x06 0x00 0x06 0x0C 0x30 0x39 0x30 0x39 0x30
	0x39
	0x30 0x39 0x30 0x39 0x30 0x39 0x3A 0xFA
Slave	0xFE 0x10 0x00 0x06 0x00 0x06 0x54 0x04

6. Dimension

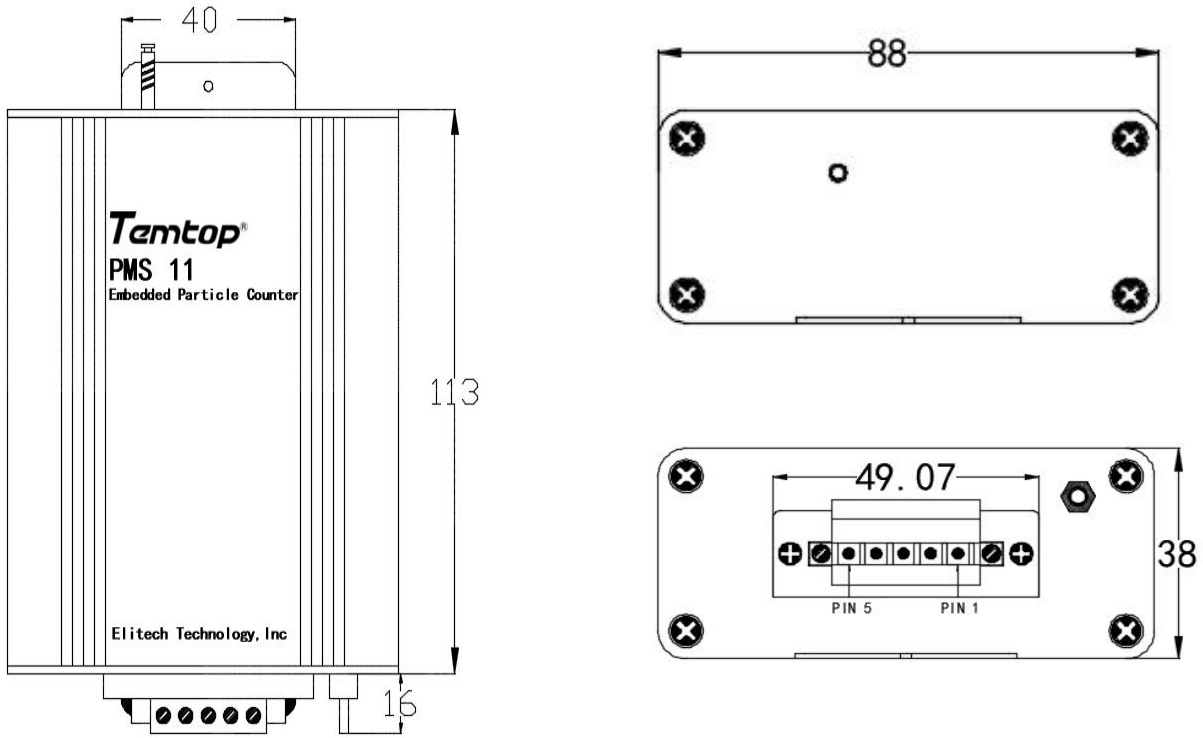

Fig.2 Dimension Drawing of PMS 11

7. Precautions for Installation and Operation

7.1 Recommended installation method

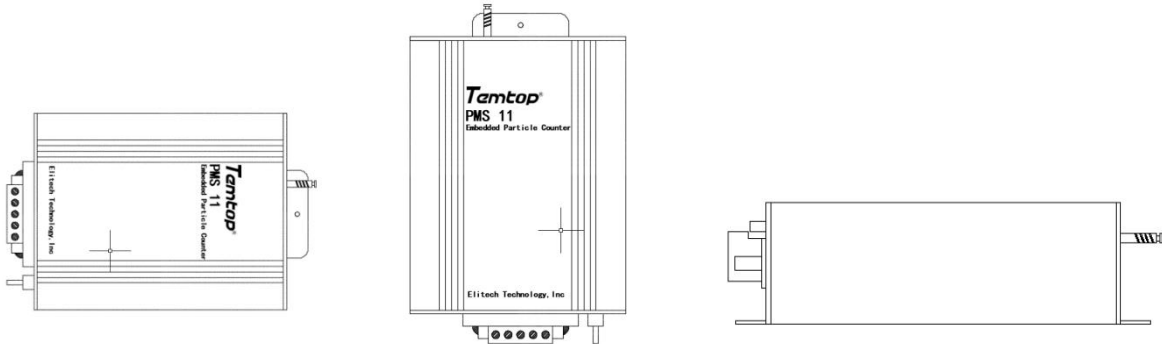

Fig. 3 Correct Installation Method

7.2 Wrong installation method

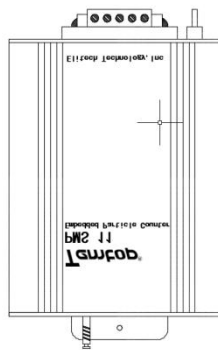

Fig. 4 Wrong Installation Method

8. Notice and Warning

CAUTION

- Please read this specification carefully before purchase, otherwise, Temtop and Elitech Technology, Inc. are not responsible for any possible danger, damage, or losses.
- As the device is not directly in contact with the monitoring environment (for example, installed in the equipment enclosures), the air inlet of the monitor shall be connected to the external probe of the enclosure, with the length of the connecting hose between them controlled within 30cm, so as to obtain accurate measurement results of sampling;
- The external probe of the enclosure shall have the ability of wind proof, coarse filtration and waterproof.

WARNING

- Please install the device referring to 8.2. It is forbidden to open the device shell for use.
- The device is equipped with a laser transmitter internally, which may cause the operation personnel to be accidentally exposed to laser radiation due to private maintenance. The maintenance of the device shall be performed by the manufacturer's special personnel.
- The implementation of product technical indicators should be used in a standard atmospheric pressure environment. The manufacturer will not be responsible for any errors in the introduction of products and data and product damage in any high-pressure/low-pressure environment.
- Elitech Technology, Inc., Temtop and Lekong (Shanghai) Environmental Technology Co., Ltd. shall not be liable for any faults caused by improper use of this product. Such faults will be deemed to be beyond the scope of warranty service, and manufacturers can provide paid service assistance.

Please be noted that the specifications, functions, interfaces, etc. of the product may be different from the content shown in the manual due to improvements and upgrades. Please kindly confirm the latest information and information with your sales representative.

Temtop US

Elitech Technology, Inc.

1551 McCarthy Blvd, Milpitas, CA 95035 USA

Tel: +1 408-898-2866

www.temtopus.com